



*Instrumentation designed  
with the user in mind*

Instruction Manual  
**Princo Models L3520 & L3521**  
Point Level Controllers with Null-Kote™

Rev 3, June 2013



---

**PRINCO INSTRUMENTS INC., 1020 INDUSTRIAL BLVD., SOUTHAMPTON, PA 18966**

PHONE: 800-221-9237 or 215-355-1500

FAX: 215-355-7766

WEB SITE: [www.princoinstruments.com](http://www.princoinstruments.com)

E-Mail: [info@princoinstruments.com](mailto:info@princoinstruments.com)

---

## Table of Contents

<b>Section 1. Description</b>	
A. General Description	1-1
B. Functional Description	1-1
C. L850, L860 & L870 Series Probe Description	1-4
<b>Section 2. Specifications</b>	
A. 1. L3520 & L3521 Level Controllers	2-1
A. 2. L850, L860 & L870 Series Probes	2-2
<b>Section 3. Installation</b>	
A. Inspection	3-1
B. Grounding	3-1
C. Probe Mounting	3-1
D. Electrical Connections	3-3
E. Installation in Hazardous Areas	3-6
<b>Section 4. Adjustments and Operation</b>	
A. Initial Checkout	4-1
B. Calibration	4-1
C. Alarm Action	4-6
D. Delay Operations and Adjustments	4-6
E. Dead Band Adjustment	4-6
F. Relay Test Function (L3520 only)	4-7
G. Diagnostic Self-Test (L3521 only)	4-7
H. Troubleshooting Guide	4-8
<b>Section 5. Equipment Service</b>	5-1

## Table of Contents

### Illustrations

Figure 1-1. Standard L853 Probe, Dimensional Drawing	1-4
Figure 1-2. Standard L853 Probe, Descriptive Drawing	1-5
Figure 1-3. Standard L870 Probe, Descriptive Drawing	1-5
Figure 3-1. L3520/21 Dimensional Drawing	3-2
Figure 3-2. Standard Installation	3-3
Figure 3-3. Extended Guard Installation	3-3
Figure 3-4. Ground Continuity Test	3-4
Figure 3-5. Electrical Connections, 115 Vac and 230 Vac	3-5
Figure 3-6. Electrical Connections, 24 Vdc	3-5
Figure 3-7. Typical Explosion-Proof Installation	3-6
Figure 4-1. L3520/21 Adjustment and Indicator Locations	4-1
Figure 4-2. Conductive Process Calibration Procedure	4-3
Figure 4-3. Non-Conductive Process Calibration Procedure	4-5

## Section One Description

### A. General Description

The Princo Models L3520 and L3521 Level Controllers are adjustable RF Impedance sensing devices which, when connected to any Princo L850 Series, L860 Series or L870 Series Probe, can be used to detect the presence or absence of process material within a storage vessel.

The basic instrument consists of an electronic chassis within a heavy-duty cast aluminum, weatherproof, explosion-proof housing. The housing has a removable lid which exposes the electronic chassis. The chassis is composed of two circular printed circuit boards which are held together by a removable system of mechanical spacers and electrical interconnects. The chassis is easily removed from the instrument housing, allowing convenient replacement, should troubleshooting be required.

The housing, with internal electronic chassis, attaches directly to any one of the Princo L850, L860, or L870 Series point level probes. An electrical and mechanical probe connection is made by simply screwing the housing directly onto the probe upper hub NPT fitting. The probe lower hub NPT fitting threads directly into the storage vessel, thus allowing probe entry into the vessel, as well as, mechanically and electrically fixturing the electronic housing and probe to the vessel construction.

The electronic chassis performs the RF impedance measurement, and compares the measurement with a set-point established by the coarse and fine sensitivity adjustments on the top of the chassis. The set-point adjustment is established by making adjustments with actual presence and absence of process material in the storage vessel. When the vessel's level passes above or below the set-point, the control relay is switched and the Sensor Status LED changes state.

### B. Functional Description

The Models L3520 and L3521 are part of a new generation of point level control switches that incorporates advanced technology to bring forth enhanced features and performance. The basic function of the device is to detect the presence or absence of process material within a storage tank or holding vessel, and to announce the process material detection in the form of an "alarmed" set of relay contacts.

The Model L3520/21, used in conjunction with a Model L850, L860, or L870 Series Sensor Probe, can detect the presence or absence of virtually any process material, from electrical insulators with low dielectric constants, to highly conductive electrical conductors. The mechanical nature of these materials can range from dry powders or granulars, to liquid materials with virtually any consistency - even thick, viscous materials that severely coat the sensor probe.

#### **1. Basic Features of Models L3520 and L3521**

- RF Impedance Sensing Measurement Technology with Null-Kote™

The L3520/21 utilizes RF impedance technology proven in tens of thousands of applications. The principle of operation is very simple: a Sensor Probe is mounted in the storage vessel. As the process material changes from not contacting the probe to contacting the probe, a corresponding change in electrical impedance occurs between the probe and the metal storage vessel wall. (For non-metallic storage vessels, a "dual element" probe is used. In this case, the impedance change occurs between the "active" and "ground" elements of the probe.)

## Section One Description

The highly sensitive impedance measurement circuits inside the L3520/21 detect and measure this electrical impedance change by means of a small radio frequency current that flows from the sensor, through the process material and back to the electronics via the metal storage vessel wall. This change in radio frequency current is converted to a proportional DC signal. This DC signal is compared to a set-point determined by the coarse and fine sensitivity adjustments, which in turn triggers a corresponding change in the states of the Probe Status LED and Output Control Relay.

- Coating Cancellation

A coating of process material on a probe can effectively simulate a presence condition, even when the process level is well below the probe. Princo point level probes incorporate a "guard" element which negates this problem. Driven by the electronic circuitry, the guard produces a correction signal, allowing the electronics to respond only to level changes above and below the "active" element of the probe. The unit must be calibrated with the probe coated for the guard to function correctly.

- Superior Temperature Stability

An advanced feature of the Model L3520/21 is its superior temperature stability. Special electronic circuitry corrects for any changes in the measurement signal due to ambient air temperature influences on the highly sensitive electronic circuits. The result is a highly temperature stable level controller. The L3520/21 can be used to reliably detect process materials with even the lowest dielectric constants.

- Heavy Duty Control Relay

Two sets of Form C (DPDT) contacts are provided via a six position terminal block (TB1) located on the top printed circuit board of the L3520/21. Both contacts are rated at 5 amps at 115 Vac.

- Probe Status Indicator

The status of the process material at the Sensor Probe is indicated by the color of the PROBE STATUS LED. The two color (Red/Green) LED is located on the top printed circuit board of the L3520/21. Green indicates material contacting the probe; Red indicates no contact.

- Coarse and Fine Sensitivity Adjustments

Two large diameter, linearly scaled, single turn potentiometers (SENS C & F) are provided on the top printed circuit board of the L3520/21. These adjustments are used to establish a repeatable switch point that is calibrated to the given process material application.

- Selectable Alarm Action

A jumper select switch is provided for programming the alarm action as either high acting, or low acting. The Alarm Select (F-S) is located on the top printed circuit board of the L3520/21.

A high acting alarm condition occurs when the process material contacts the probe (presence). A low acting alarm condition occurs when the process material is removed from the probe (absence). In both cases the "alarm" condition is defined as a de-energized control relay.

## Section One Description

- Fail Safe Alarm Action

The L3520/21 is in normal “non-alarmed” state when its control relay is energized. If the unit were to lose power, the control relay would de-energize. Thus a power failure would produce an alarm condition, alerting the operator that a problem exists.

- Time Delay Adjustment

The L3520/21 senses the process material level change instantaneously. However, a delay can be inserted between the instant the instrument senses the level change, and the time the control relay correspondingly changes state. A single turn TIME DELAY pot is provided on the top printed circuit board of the unit. This potentiometer allows an adjustment of 0 to 30 seconds of time delay.

The time delay feature is useful when process material wave action causes the control relay to continually change state. It can also be used to suit a particular control timing application. Note that the PROBE STATUS LED changes immediately, even when a delay is applied.

- Dead Band Adjustment

The L3520/21 provides a Dead Band adjustment. A single turn DEAD BAND pot is provided on the top of the unit. The Dead Band is the span between the level at which the L3520/21 recognizes the change from absence to presence, and the level at which it recognizes the change from presence to absence. It applies mainly to vertically installed probes in non-conductive process material applications. The Dead Band adjustment is used primarily to compensate for settling and packing when the process material is a low dielectric constant granular or powder.

### **2. Additional Feature of Models L3520**

- Relay Test Function

The L3520 has a front panel TEST push-button, which, when pushed, checks the operation of the control relays and any device driven through them.

### **3. Additional Feature of Models L3521**

- Diagnostic Self-Test

This self-test feature checks all the functional stages of the electronic circuitry, from the sensing oscillator to the output control relay. It may be initiated manually by a front panel TEST push-button, or remotely by a 24 Vdc signal. Indication is visual through change in the color of the PROBE STATUS LED.

## Section One Description

### C. L850, L860 & L870 Series Probe Description

L850, L860 and L870 Series Sensor Probes are the probes commonly used with the L3520/21. (Refer to Figure 1-1 for a dimensional drawing of the standard L853 Probe.) These probes have three stainless steel electrical contacts - active, guard and ground - which are separated from each other by Teflon insulators. See Figures 1-2 and 1-3 for location of these contacts on the L853 and L870 probes respectively. Electrical contact between the probe elements and the electronic unit is made by simply threading the probe into the electronic housing. The "active" element contacts the L3520/21 circuit board by means of the spring-loaded pin projecting from the top of the probe. The guard contact is made by means of a 1/2 inch diameter spring which projects from the bottom of the L3520/21 bottom circuit board. This spring fits concentrically around the spring-loaded pin and touches the guard contact on the probe. The hub of the probe serves as the ground element. It contacts both the electronic housing and the metal storage vessel through its threaded connections with them.

The guard element cancels the effect of any process coating between the active and ground elements, allowing the unit to respond only to process level changes.

All of the L850, L860 and L870 Series Probes have these same three elements, varying only in physical dimensions and configuration as required for various applications.

The L854 and L870 Probes have built-in ground references and are referred to as "dual element" probes. They are suitable for various low dielectric and/or non-metallic tank applications. The L870 (Figure 1-3) has a ground rod in parallel with the standard active/guard rod. The L854 (not shown) has a 3/4 inch diameter stainless steel tube concentrically surrounding the standard active/guard rod. The tube itself serves as the ground element. Various L100 Series Probes are sometimes used for special applications. Refer to Princo Bulletin L-96-6 for dimensional details on L850, L860 and L870 Series probes.

Probes are available in custom guard lengths and overall lengths, above and below the standard lengths. Teflon and Kynar sheathed probes are available for applications where stainless steel is incompatible with the process material. Consult the factory for specific application questions.

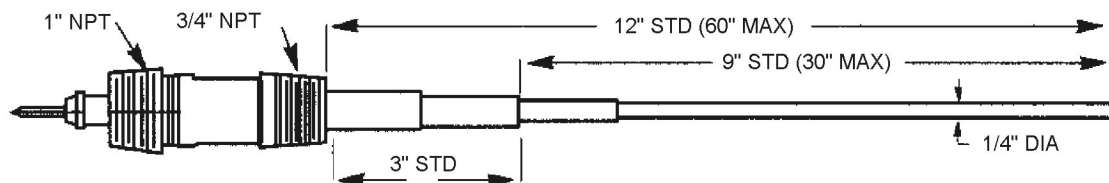

Figure 1-1  
Standard L853 Probe, Dimensional Drawing

# Section One Description

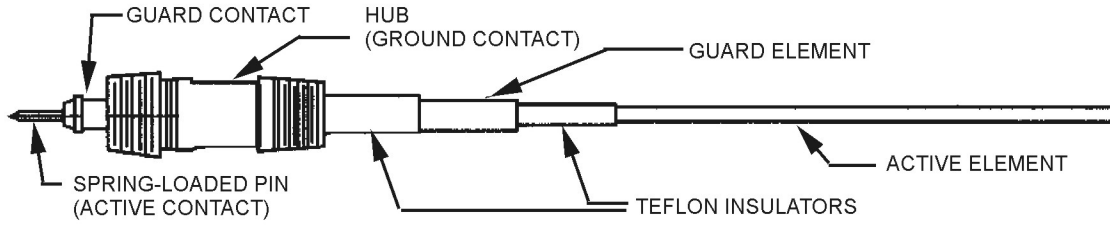

Figure 1-2  
Standard L853 Probe, Descriptive Drawing

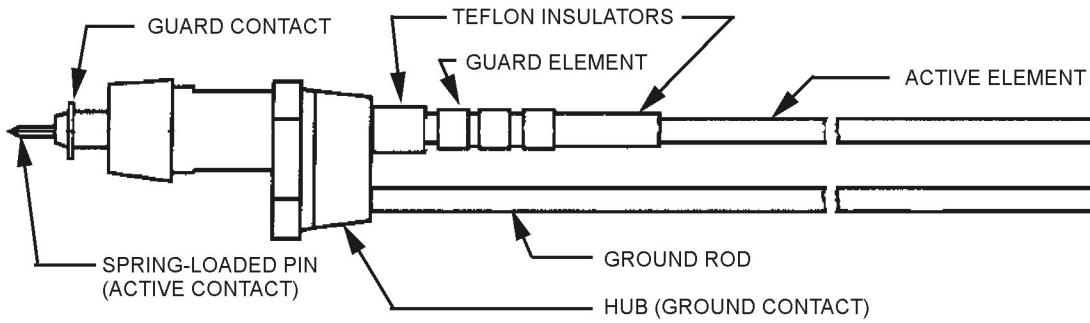

Figure 1-3  
Standard L870 Probe, Descriptive Drawing



## Section Two Specifications

### A. Specifications

#### 1. L3520 & L3521 LEVEL CONTROLLERS

- **TYPE**  
Point type (on/off), solid state electronic, high frequency (RF), impedance-sensing, level controller.
- **POWER REQUIREMENTS**  
95 to 135 Vac, 50 to 60Hz, 1.3 watts; or 205 to 250 Vac, 1.3 watts; or 12/34 Vdc, <1 Watt.
- **AMBIENT TEMPERATURE RANGE**  
-40 to 150 °F (-40 to 66 °C)
- **SENSITIVITY**  
Senses capacitance as low as 0.15pF. Sensitivity may be decreased to approx. 1000pF.
- **TEMPERATURE STABILITY**  
Less than 1.0 pF typical (-40 °F to +150 °F).
- **ALARM TYPE**  
Selectable as either High Acting or Low Acting.  
High Acting : Alarm occurs upon presence of process material.  
Low Acting : Alarm occurs upon absence of process material.
- **ALARM ACTION**  
Fail Safe Alarm : Control relay de-energizes (drops out) upon alarm.
- **CONTROL RELAY CONTACTS**  
L3520: Two sets of form C contacts, rated at 5 amperes, 115 Vac or 26 Vdc, resistive load.  
(Two sets of form C contacts, rated at 10 amperes, 115 Vac or 26 Vdc, resistive load for units made prior to February 1, 2011.)  
L3521: Two sets of form C contacts, rated at 5 amperes, 115 Vac or 26 Vdc, resistive load.  
(Two sets of form C contacts; one rated at 10 amperes, 115 Vac or 26 Vdc; the other rated at 2 amperes, 115 Vac or 26 Vdc, resistive load for units made prior to February 1, 2011.)
- **DELAY TIME AND DELAY MODE OPTIONS**  
Standard time delay is adjustable from 0 to 30 seconds. Standard mode is delay both ways (turn-on alarm and turn-off alarm). Consult the factory for optional times and modes.
- **DEAD BAND**  
Adjustable over range of 1.3pF for low values of process capacity. Adjustment range increases with sensitivity control setting, up to approximately 1000pF, for high values of process capacity.

## Section Two Specifications

- **ELECTRONIC HOUSING**

Heavy duty, cast aluminum.

Explosion-proof for: Class I, groups C & D; Class II, groups E, F & G.

Weather proof: NEMA 4.

## 2. L850, L860 & L870 SERIES PROBES

- **TYPE**

Point level, single or dual element.

- **PRESSURE / TEMPERATURE RATINGS**

PSI	@	TEMP °F
1000	@	-300
1000	@	100
450	@	300
350	@	400
0	@	500

- **WETTED SURFACES**

Teflon and 316 Stainless Steel are standard. Probes fully sheathed in Teflon or Kynar are also available.

- **VESSEL CONNECTION SIZE**

L850 Series: 3/4" NPT; L860 Series: 1" NPT; L870 Series: 1½" NPT.

- **PHYSICAL DIMENSIONS**

Refer to Figure 1-1 and Princo Level Probes Bulletin.

## Section Three Installation

### A. Inspection

The L3520/21 Level Controller is normally supplied with one of the Princo L850, L860, or L870 Series Level Probes. The L3520/21 and probe are shipped in separate packages.

Carefully remove each package's contents and check each item against the packaging list. Inspect each item for shipping damage. In particular, check the spring-loaded pin, located on the threaded hub end of the probe (see Figures 1-2 and 1-3). This pin provides the necessary electrical connection from the L3520/21 bottom printed circuit board, to the active element of the probe. Make sure this pin is not missing, bent, jammed, or otherwise damaged.

If the probe is a Teflon or Kynar sheathed probe, carefully inspect the condition of the sheathing. Make sure the sheathing forms a smooth continuous coverage over the probe. Discontinuities in the sheathing material which breach through to the probe elements may render the probe useless in certain applications. Report any such damage immediately to the factory.

#### CAUTION !

Care must be exercised when handling probes which incorporate an insulating sheath. Do not allow the sheathed sensing element to come in contact with a rough or sharp surface, as this may cause a breach in the insulating sheath, and render the probe inoperable.

### B. Grounding

Reliable operation of the L3520/21 Level Controller will only occur through proper installation. The most important installation consideration is a proper sensor ground return.

If the process storage tank is metal, and the probe is a single element type, the ground return connection is made when the probe is properly mounted in the vessel (see C. Probe Mounting).

Non-metallic vessels (eg. plastic, concrete, etc.), require a dual element probe which has a built-in ground return rod (L854 and L870 Probes). A single element probe may be adapted to the same purpose by providing a ground return. The ground return should consist of a metal rod, equal in length to the probe. The rod should be mounted parallel to the length of the probe, no greater than 6 to 8 inches from it.

The ground return rod must be electrically connected to the L3520/21 housing or to the ground position of the terminal block (TB2) with 18 AWG or heavier wire. See Figures 3-5 and 3-6. See Figure 3-4 for ground continuity testing.

### C. Probe Mounting

The probe is mounted by its NPT hub or flange. Refer to Figure 3-1, 3-2, and 3-3 for mounting details and dimensions.

If the process material in the storage vessel is electrically conductive, the probe can be mounted in either a vertical or horizontal orientation. If the probe is mounted vertically, and the process material is electrically conductive, the L3520/21 will be tip sensitive (i.e. the L3520/21 trip point will occur when the process material just contacts the tip of the probe).

If the process material in the storage vessel is electrically non-conductive (i.e. non-conductive liquid, dry powder or granular), it is recommended that the probe be mounted in a horizontal orientation. A vertically installed probe in a non-conductive process material, may require up to six inches of probe immersion before a stable trip point is reached.

## Section Three Installation

In horizontal mount applications, it is recommended that the probe be mounted at a shallow downward angle (not critical) off the horizontal axis for optimum process liquid drainage (refer to Figures 3-2 and 3-3).

In applications where the probe is installed through a nozzle, the guard element should extend two inches into the vessel, beyond any process material coating build-up on the vessel inner wall (see Figure 3-3).

To mount the equipment, screw the NPT hub of the probe into the NPT mounting collar which is welded into the wall or top of the storage vessel. After mounting the probe, screw the electronic housing onto the terminal end of the probe. This is all the support it requires.

### NOTE

Do not use any type of thread lubricant on the NPT probe mounting threads or the NPT threads which mount the electronic housing. Application of thread lubricant may cause faulty or improper ground connection. If required, Teflon tape may be used as a thread seal for either threaded connection. If Teflon tape thread sealant is used, the installer should make an electrical continuity check with a hand held ohm meter. Continuity should exist between the storage vessel and the equipment electronic housing. Less than 1 ohm resistance should exist between these two points. See Figure 3-4.

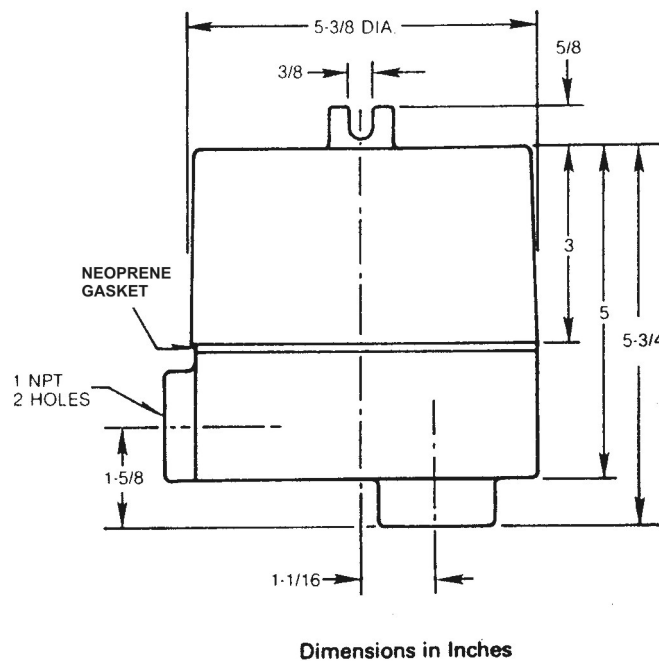

Figure 3-1  
L3520/21 Dimensional Drawing

### Section Three Installation

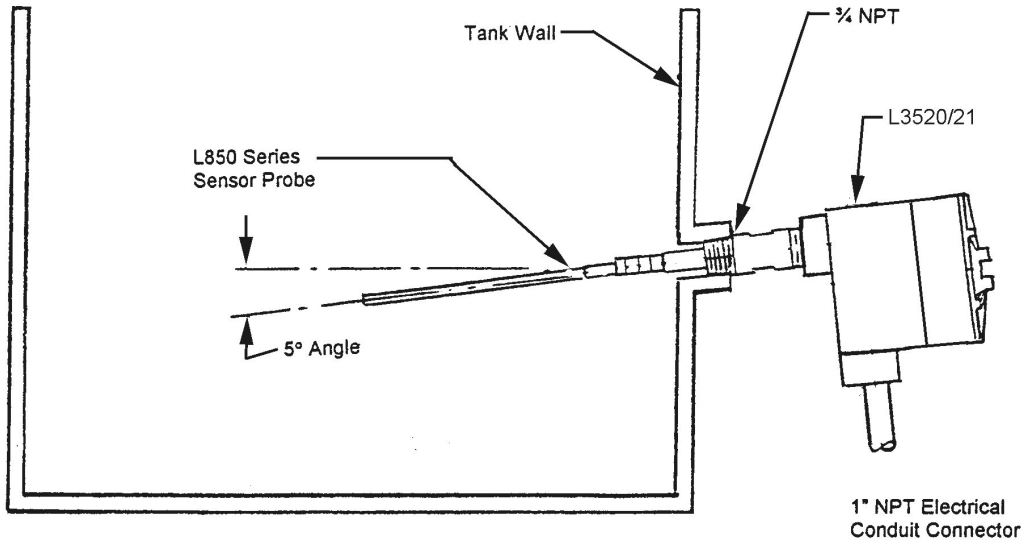

Figure 3-2  
Standard Installation

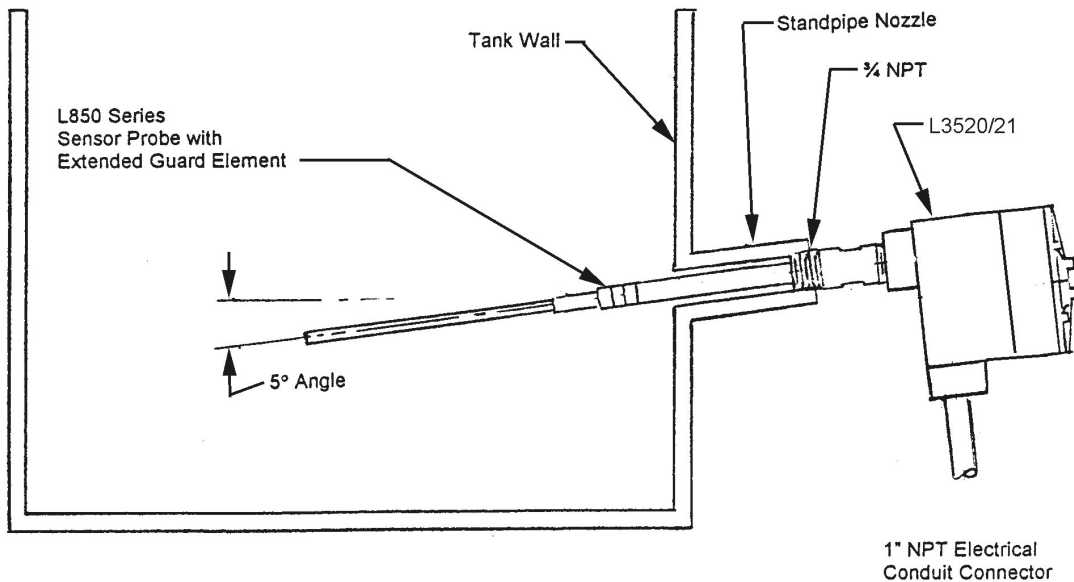

Figure 3-3  
Extended Guard Installation

#### D. Electrical Connections

Remove the lid of the L3520/21 electronic housing in preparation for connection of input and output wires. Before drawing wires into the equipment housing, it may be necessary to remove the electronic chassis. To do so, unfasten the two 8-32 mounting screws which are located on either side of the terminal strips. Once screws are unfastened, the chassis may be lifted or

## Section Three Installation

removed from the housing. The power and relay contact wires may now be pulled through the one inch NPT wiring port.

Connect the 115 Vac or 230 Vac power line wires: Hot (H), Neutral (N), and Ground (G) respectively, to the right terminal strip (TB2) as shown in Figure 3-5. If the unit requires 24 Vdc for power, the terminal strip TB2 is labeled as plus (+), minus (-) and ground (G). Connect 24 Vdc power accordingly as shown in Figure 3-6.

Connect the normally open (NO), normally closed (NC) and common (C), relay wires to the left hand terminal strip (TB1) as shown in Figure 3-5, and Figure 3-6, and as required by the specific circuit application.

### NOTE

The relay contact configuration, shown in Figures 3-5 and 3-6, and labeled on the instrument overlay panel surface, is identified as such with the relay in the de-energized (shelf) state. Fail safe operation requires the relay to be "normally" in the energized (non-shelf) state. Upon alarm, configured as either HIGH or LOW, the relay then becomes de-energized (shelf state), as per Figure 3-5, 3-6, and TB1 labeling.

Replace the electronic circuit board chassis with the flat side of the printed circuit boards facing the wiring port. Replace mounting screws and tighten.

### NOTE

The two 8-32 mounting screws **MUST** be fastened securely. These two screws provide the ground connection to the printed circuit board electronics. If not fastened securely, faulty equipment operation may occur.

Verify that all connections were made correctly.

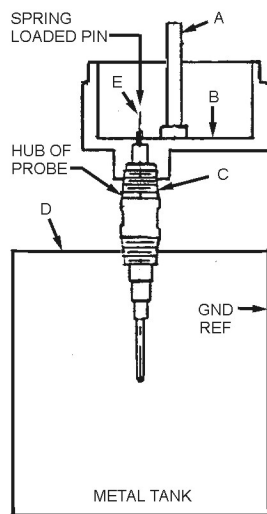

### Ground Continuity Test:

With unit power off, using an ohmmeter on the lowest range, a check between the following points should yield less than one ohm.

1. Point A (posts) to point B.
2. Point B to point C.
3. Point C to point D (except in non-metallic tank).

Figure 3-4  
Ground Continuity Test

## Section Three Installation

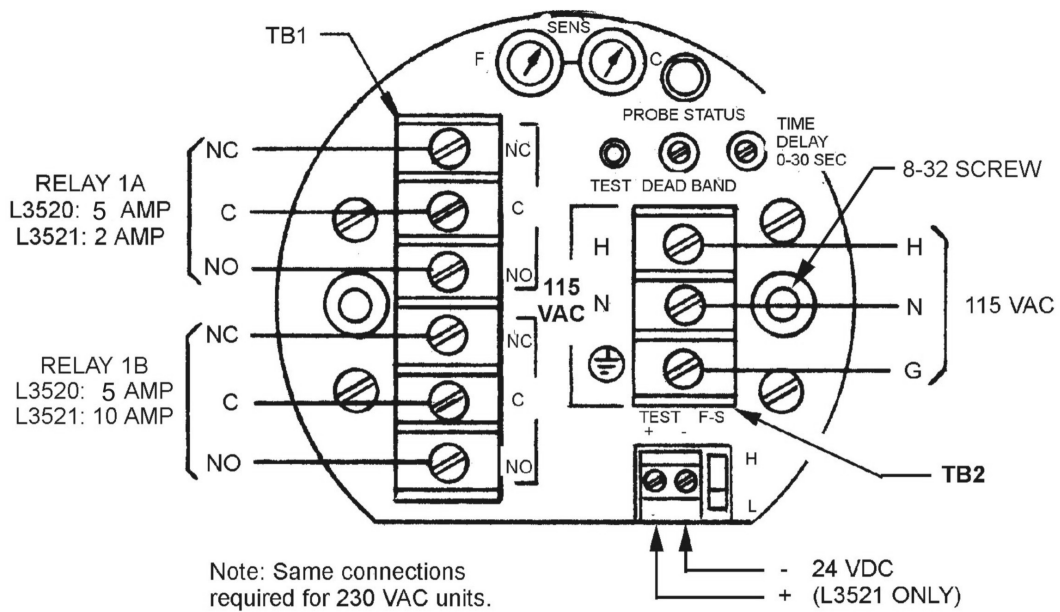

Figure 3-5  
Electrical Connections, 115 Vac and 230 Vac

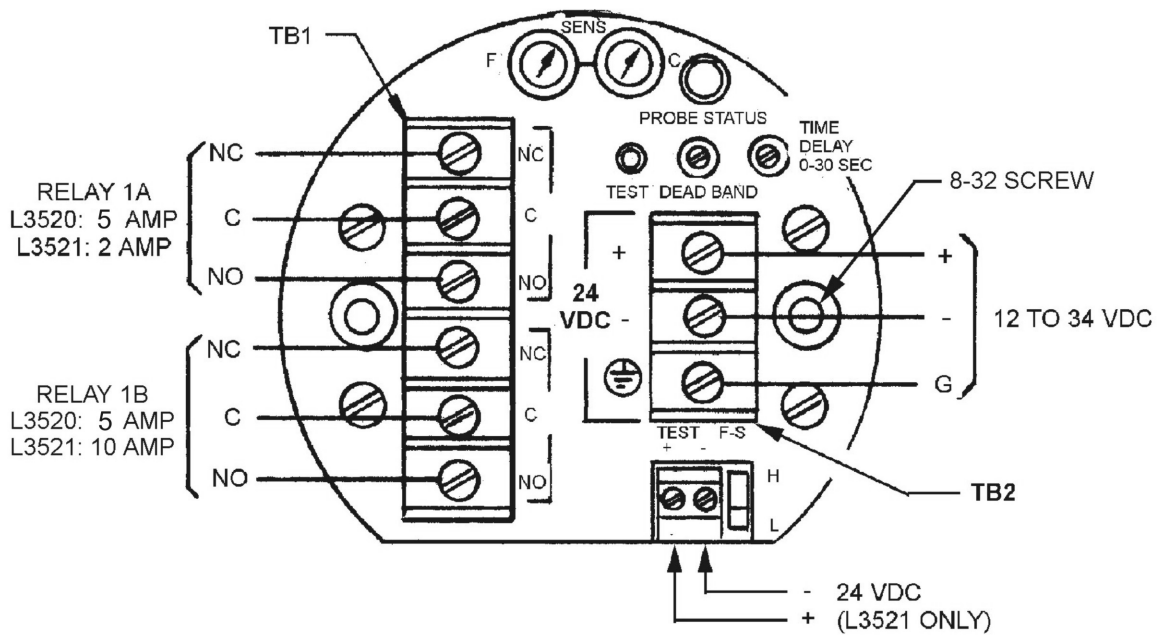

Figure 3-6  
Electrical Connections, 24 Vdc

## Section Three Installation

### E. Installation in Hazardous Areas

The outline which follows points out some of the major requirements of the NEC's (National Electric Code) Section 501, as it relates to typical level control installations.

#### WARNING !

For applications which **MUST BE** explosion-proof and/or weatherproof, it is the customer's responsibility to install the required conduit, seals, wiring, etc., which meet national, as well as applicable local and plant safety codes. See Figures 3-7 and 3-8 below.

For Class 1 locations, rigid metal conduit must be used. At least five full threads of the conduit must be tightly engaged in the enclosure. Conduit seal fittings must also be used. These seal fittings, must be filled with an approved sealing compound and must be installed within 18 inches (or closer) of the enclosure. Conduit seals are also required when the conduit passes from a hazardous area into a non-hazardous area. Water drain seal fittings eliminate or minimize the effect of water which tends to collect in the conduit or enclosure due to condensation.

Approved wire type, such as mineral-insulated wire, is required for use in Division 1 installations. Certain types of metal-clad cable or shielded non-metallic sheathed cable are permitted in Division 2 installations. When multiconductor cables are used in the conduit, the outer jacket must be cut away in such a manner that allows the sealing compound to surround each insulated wire as well as the jacket.

The preceding information should act as guide to assist the customer/installer in satisfying their responsibility for producing safe installations in hazardous area.

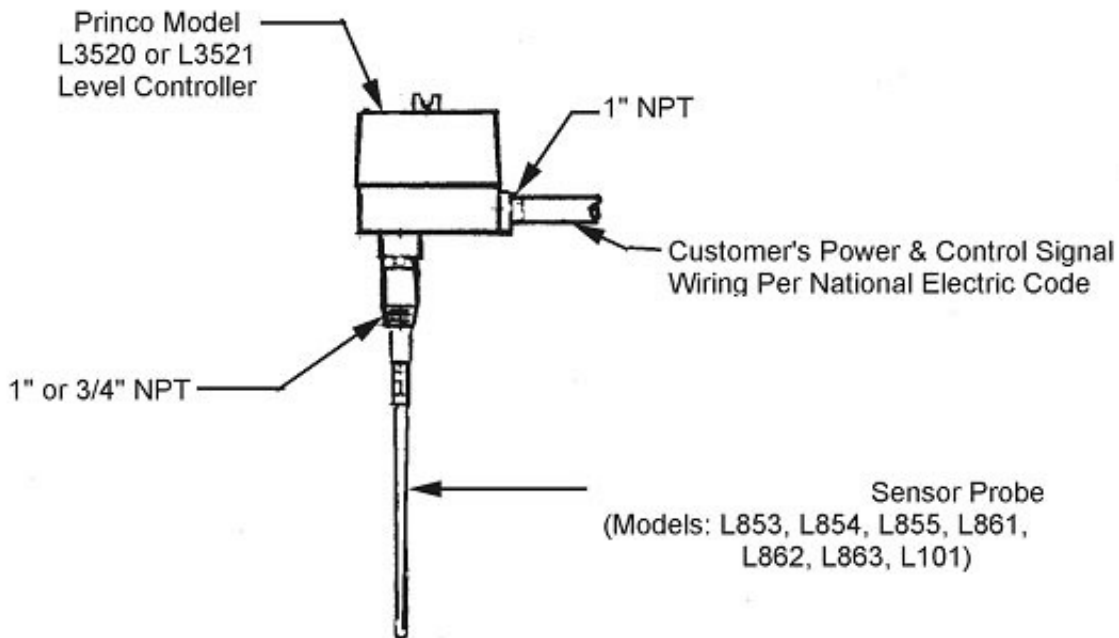

Figure 3-7  
Typical Explosion-Proof Installation



## Section Four Adjustments and Operation

### A. Initial Checkout

1. Refer to Figure 4-1 for L3520/21 adjustment and indicator locations.
2. Install the L3520/21 Level Controller with Probe as presented in Section 3 of this manual.
3. Apply power to the unit.
4. Perform Section Four, step H.1: Basic Electronic Checks.

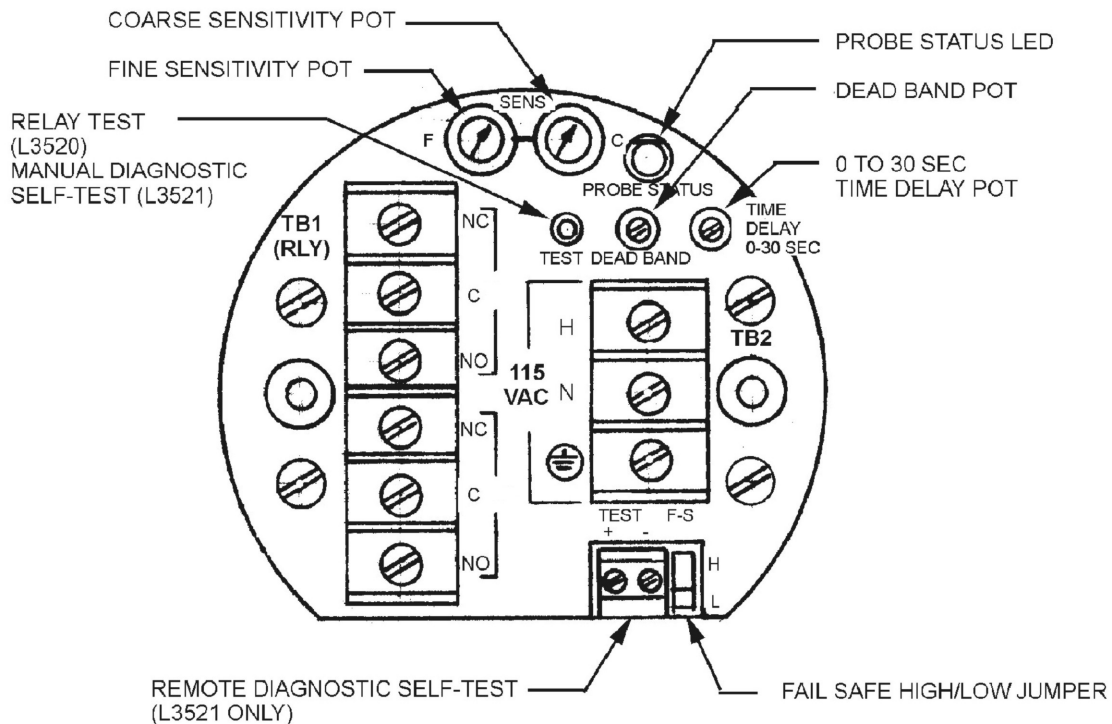

Figure 4-1  
L3520/21 Adjustment and Indicator Locations

### B. Calibration

The Coarse (C) and Fine (F) sensitivity (SENS) pots must be properly adjusted in order to establish a repeatable switch point for the given process material.

If the process material is electrically conductive, then adjustments can be made under simulated or "bench test" conditions.

To make adjustments under simulated conditions, perform the following outlined procedure by raising and lowering the L3520/21, with attached probe, into and out of a small metallic vessel filled with the conductive process material. Perform the procedure making certain that nothing

## Section Four Adjustments and Operation

but the process material, contacts the probe. A clip lead must be connected from the L3520/21 metal housing to the metal wall of the vessel used.

Whether adjustments are made under simulated conditions, or in the actual proper installation, the following procedure must be performed:

### **1. ADJUSTMENT PROCEDURE - Conductive Process Materials**

- a) Refer to Figure 4-1 for adjustment and indicator locations. Refer to Figure 4-2 for a pictorial outline of this procedure.
- b) Perform Section 4.A., Initial Checkout, as outlined above.
- c) Allow the unit to warm up (thermally stabilize) for approximately 15 minutes before proceeding with steps d through j below.
- d) Preset Coarse (C) and Fine (F) sensitivity (SENS) potentiometers to mid-point positions (12 o'clock).
- e) Turn the TIME DELAY and DEAD BAND pots to the fully counter-clockwise position (no Delay, minimum Dead Band)
- f) If a coating is likely to build up on the probe in actual use, pre-coat the probe with the process material before proceeding. Coating must cover the entire length of the probe, including the guard element. This may be done by raising the level or by other means.
- g) With process material NOT contacting the probe, adjust the Coarse (C) sensitivity such that the PROBE STATUS LED "just turns" Green. Mark the Coarse (C) pot screwdriver slot or mentally note its position.

#### NOTE

Clockwise rotation increases sensitivity for both Coarse (C) and Fine (F) potentiometers.

- h) Immerse probe in process material to the desired level of "trip point". For a vertically installed sensor probe in a conductive process material, this trip point should be at the tip of the probe active section.

#### NOTE

Conductive process materials will tend to "trip" near the tip of the probe when the storage tank is metallic. This same procedure may be used even though the probe is to be mounted horizontally.

- i) With probe immersed, adjust the Coarse (C) sensitivity pot counter-clockwise such that the PROBE STATUS LED "just turns" Red. Mark or mentally note position of screwdriver slot.
- j) Turn probe Coarse (C) sensitivity pot until the screwdriver slot is midway between the marks from steps g and i. The PROBE STATUS LED should now be Green (probe immersed in same position). If not repeat steps f through j.

#### NOTE

A Green PROBE STATUS LED denotes presence of material at the probe, and a Red LED denotes absence of material at the probe, when sensitivity potentiometers are properly adjusted.

## Section Four Adjustments and Operation

Begin with TIME DELAY and DEAD BAND full counter-clockwise, probe coated.

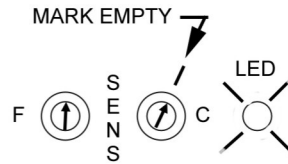
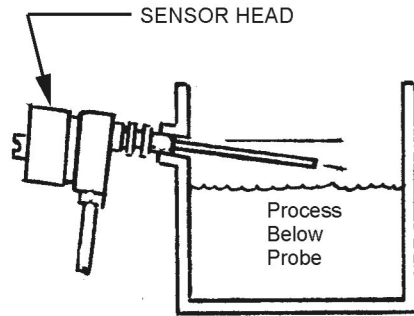

1. Start with process below probe.
2. Adjust F and C to mid way (12 o'clock).
3. Slowly adjust C to turn "just green".
4. Mark empty.

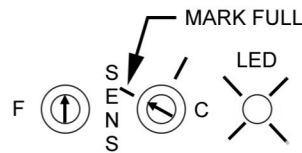
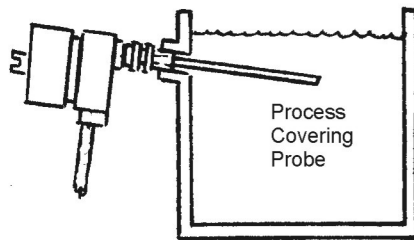

1. Raise the process to cover probe.
2. Adjust C counterclockwise to turn "just red".
3. Mark full.

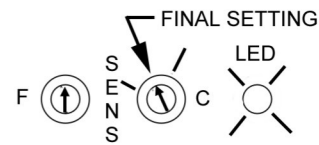
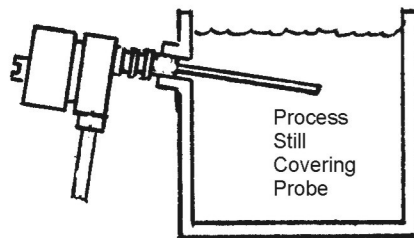

1. Adjust C half way between both marks.
2. LED turns red when process drains below probe.
3. LED turns green when process covers probe.

Figure 4-2  
Conductive Process Calibration Procedure

## Section Four Adjustments and Operation

### **2. ADJUSTMENT PROCEDURE - Non-Conductive (Insulating) Process Materials:**

- a) Refer to Figure 4-1 for adjustment and indicator locations. Refer to Figure 4-3 for outline of this procedure.
- b) Perform Section 4.A., Initial Checkout, as outlined above.
- c) Allow the unit to warm up (thermally stabilize) for approximately 15 minutes before proceeding with following steps.
- d) Preset the Fine Sensitivity pot (F) full clockwise and the Coarse Sensitivity pot (C) to the mid-point position (12 o'clock).
- e) Turn the TIME DELAY and DEAD BAND pots to the fully counter-clockwise position (no Delay, minimum Dead Band).
- f) If a coating is likely to build up on the probe in actual use, pre-coat the probe with the process material before proceeding. The coating must cover the entire length of the probe, including the guard element. This may be done by raising the level or by other means.
- g) With process material NOT contacting the probe, adjust the Coarse (C) sensitivity pot such that the PROBE STATUS LED "just turns" Green and stays. Don't touch the Coarse (C) sensitivity pot again.

#### NOTE

Clockwise rotation increases sensitivity for both Coarse (C) and Fine (F) potentiometers.

- h) Adjust the Fine (F) sensitivity pot counter-clockwise, such that the PROBE STATUS LED "just turns" Red, and then back clockwise until it "just turns" Green. Mark the position of the Fine (F) sensitivity pot.
- i) Immerse probe in process material to the desired level of "trip point". For a vertically installed sensor probe in a non-conductive process material, this trip point should typically be half way up the probe active section.

#### NOTE

Horizontal probe mounting is preferred (see Section 3C). The procedure must be done with the L3520/21 properly installed in the intended storage tank, and with the intended process material. All or most of the probe may need to be covered. The angle between the adjustment marks may be quite small with non-conductive process materials.

- j) With probe immersed, adjust the Fine (F) sensitivity pot counter-clockwise, such that the PROBE STATUS LED "just turns" Red and stays. Mark or mentally note position of screwdriver slot.
- k) Turn the Fine (F) sensitivity pot until the screwdriver slot is midway between the marks from steps h and j. The PROBE STATUS LED should now be Green (probe immersed in same position). If not repeat steps f through k.

#### NOTE

A Green PROBE STATUS LED denotes presence of material at the probe, and a Red LED denotes absence of material at the probe, when sensitivity potentiometers are properly adjusted.

## Section Four Adjustments and Operation

Begin with TIME DELAY and DEAD BAND full counter-clockwise, probe coated.

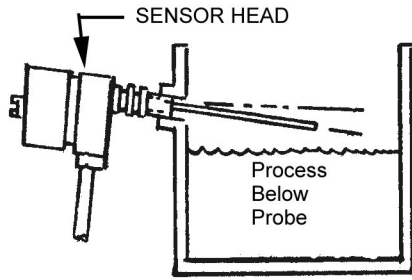

1. Start with process below probe.
2. Adjust F full clockwise and C to mid way (12 o'clock).
3. Slowly adjust C to turn "just green".

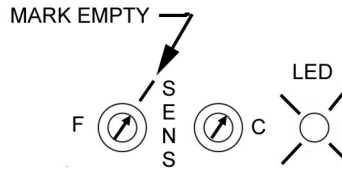
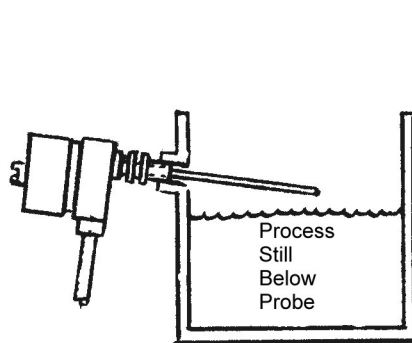

1. Slowly adjust F counterclockwise to turn "just red", and back clockwise to "just green".
2. Mark empty.

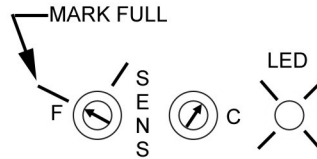
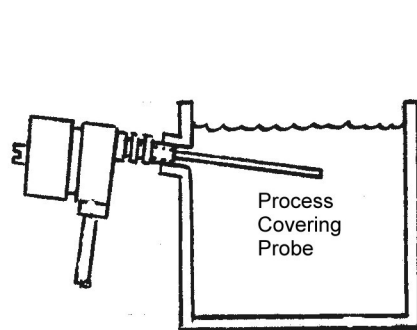

1. Raise the process to cover probe.
2. Slowly adjust F counterclockwise to turn "just red".
3. Mark full.

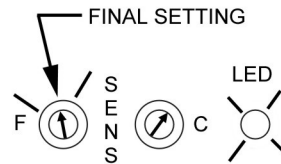
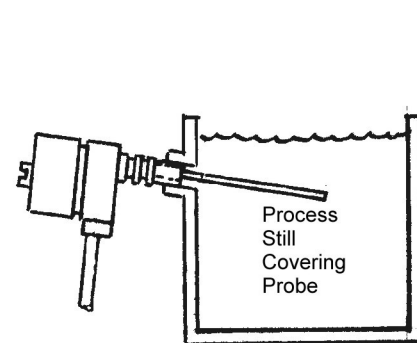

1. Adjust F half way between both marks.
2. LED turns red when process drains below probe.
3. LED turns green when process covers probe.

Figure 4-3  
Non-conductive Process Calibration Procedure

## Section Four Adjustments and Operation

### C. Alarm Action

The L3520/21 is in the normal “non-alarmed” state when its control relay is energized. The unit is in the “alarm” state when its internal control relay is de-energized. Hence, if the unit lost power, the internal control relay would de-energize, and an “alarm” condition would occur.

This type of “Fail-Safe” operation is based on the fact that most major malfunctions, including a power failure, would cause the control relay to de-energize.

#### 1. Fail Safe Low Operation (Low Acting Alarm):

The control relay contacts de-energize (shelf state) upon Low Alarm. When process material absence is detected, a Low Alarm condition occurs, and the relay changes from the normal “non-alarmed” (energized) state to the “alarmed” (de-energized) state.

#### 2. Fail Safe High Operation (High Acting Alarm):

The control relay contacts de-energize (shelf state) upon High Alarm. When process material presence is detected, a High Alarm condition occurs, and the relay changes from the normal “non-alarmed” (energized) state to the “alarmed” (de-energized) state.

This action is controlled by a small plastic jumper selector switch (F-S) located on the top of the unit. (Figure 4-1). The L circuit pad designates Low Acting Alarm. The H circuit pad designates High Acting Alarm. The center pad is the common, and always connects to one position of the jumper selector.

Unless otherwise specified this unit is set for High Acting Alarm operation. If Low Acting Alarm operation is desired, remove the jumper switch currently connected between center pin and H, and re-locate it between center pin and L.

### D. Delay Operations and Adjustments

Time delay is useful in preventing control relay “chatter” from agitation of the process material within the storage vessel. It is also useful in certain process control timing applications. The three types of time delay are as follows: delayed turn-on alarm, delayed turn-off alarm, and delayed turn-on alarm / turn-off alarm.

The first two modes are normally used to suit a particular timing application. The third mode (turn-on / turn-off) is best suited to prevent relay chatter. This mode (on/off) is factory configured in the standard L3520/21 unit.

A single turn TIME DELAY pot is provided on the L3520/21 (see Figure 4-1). Most applications require no time delay. Therefore, adjust the TIME DELAY pot to the maximum counter-clockwise direction (zero time delay).

If there is significant agitation of the process material within the storage vessel, then time delay may be required. In this case, adjust the TIME DELAY pot clockwise, just enough to prevent control relay chatter. Use the smallest amount of delay possible.

The maximum standard delay time is 30 seconds full scale. Consult Factory for optional delay times and modes.

### E. Dead Band Adjustment

The Dead Band is the band of level corresponding to the points at which the L3520/21 recognizes process material presence and process material absence. It applies primarily to vertically installed probes in non-conductive process material applications. The dead band

## Section Four

### Adjustments and Operation

adjustment is used primarily to compensate for settling and packing when the process material is a low dielectric constant granular or powder.

A given dead band adjustment represents a certain physical distance on the sensor probe over which the process material has to move in order for the level control to change from a non-alarm to an alarm condition, and vice versa. (An absolute zero dead band would result in extreme relay chatter when the level was at the set point.)

The physical distance of this band, for a given dead band adjustment, is greater for less responsive process materials (i.e. low dielectric constant process materials) than it is for high response process materials (i.e. high dielectric constant, or conductive process materials).

When the Dead Band pot is turned clockwise, the trip point opens up into an ever increasing band, above and below the original set point. In a fail safe high application, the control relay would energize at the bottom point, and de-energize at the top point. In a fail safe low application, the control relay would energize at the top point of the dead band, and de-energize at the bottom point.

Accordingly, adjust the DEAD BAND pot clockwise (see Figure 4-1) just enough to compensate for the adverse process effect in question (i.e. process material settling and packing). Note that the action of the Dead Band adjustment will be defeated in applications where the process liquid is conductive and the sensor probe is not sheathed.

Although the L3520/21 is not designed as a zone controller, it may be used as such in some applications. The on/off zone can be established experimentally by varying the DEAD BAND pot. Once the desired zone is established, operation must be monitored for a period of time to determine whether the repeatability is acceptable for the application.

#### F. Relay Test Function (L3520 only)

This function tests the operation of the control relays and any devices which might be slaved to their contacts. Depressing the TEST push-button on the top of the L3520 changes the control relays from the "non-alarmed" (energized) state to the "alarmed" (de-energized) state. Pressing the push-button while the relays are in the "alarmed" state produces no change.

#### G. Diagnostic Self-Test (L3521 only)

The diagnostic self-test checks all functional stages of the L3521 electronics, from the sensing oscillator to the output relays. This test may be activated locally or remotely.

To turn on the test function locally (at equipment site), press the TEST push-button (see Figure 4-1). If the L3521 is set up for Fail-Safe High operation, the sensitivity potentiometers adjusted to suit a particular high level application, and the process material is below the sensing probe, the PROBE STATUS LED will change from Red to Green and the control relay will actuate (de-energize).

If the L3521 is set up for Fail-Safe Low operation, the Sensitivity potentiometers adjusted to suit a particular low level application, and the process material is surrounding the sensing probe, the PROBE STATUS LED will change from Green to Red, and the control relay will actuate (de-energize) when the Test push-button is pushed.

## Section Four

### Adjustments and Operation

Computer or power supply initiation of the Diagnostic Self-Test from a remote location can be accomplished by applying a 24Vdc signal to the Test terminals (see Figure 4-1). Application of such a signal will have the same effect as pushing the TEST push-button as described above.

#### H. Trouble-Shooting Guide

##### 1. Basic Electronic Checks

- ✓ The Probe Status LED should be lit to either Red or Green at all times. If not, check that proper power is applied to the Power terminals.
- ✓ With both the Coarse (C) and Fine (F) sensitivity potentiometers turned fully clockwise, the LED should be Green. With both potentiometers turned fully counter-clockwise the LED should be Red.
- ✓ The LED should switch crisply from Green to Red or from Red to Green. It should never hang in between in an orange color.

If the unit fails any of the above checks, return the L3520/21 electronic chassis to the factory for repair or replacement.

##### 2. Adjustment Problems

- After performing the adjustment procedure, the unit fails to shut off or on properly.
- ✓ Check ground continuity (refer to Figure 3-4).
- ✓ Check that the spring-loaded pin on the top of the probe (see Figures 1-2 and 1-3) is making contact with the silver pad on the bottom of the electronic circuit board. The pin normally projects about 1¼ inches above the NPT fitting on the probe. It may be stretched out further with a pair of pliers without causing damage.
- ✓ Be sure that non-immersed and immersed conditions really exist when making the appropriate adjustments

#### NOTE

When performing the adjustment procedure, there should be a noticeable change in the position of the Coarse (C) Sensitivity potentiometer for conductive processes and in the position of the Fine (F) Sensitivity potentiometer for non-conductive processes between the non-immersed and immersed adjustment points. If there is not, the electronic unit is not seeing any change, probably due to one of the above conditions.

- Unit switches correctly once or several times and then fails to switch correctly.
- ✓ A progressively thicker coating may be building up on the probe. This would result in a narrower span between the non-immersed and immersed positions of the sensitivity potentiometer when performing the adjustment procedure.  
Solution: This condition will require performing the adjustment procedure over again when the coating is at its thickest point.



## Section Four

### Adjustments and Operation

- ✓ There may have been a change in the dielectric constant of the process material. This would change the flow of RF current through the probe, effectively shifting the switch point. Solution: RF impedance technology is designed to operate with materials having a constant dielectric constant (therefore, a constant RF conductivity). It may be possible, through trial and error, to find a switch point that works for some changes in dielectric constant; but extreme changes, like oil to water, may be impossible to compensate for. As a general rule, a unit adjusted to a low dielectric constant will switch correctly when a material of higher dielectric constant is applied (although at a point closer to the tip of the probe). However, changes in the coating characteristics could negate this effect.

## Section Five Equipment Service

### Getting Help

If your Princo equipment is not functioning properly, and attempts to solve the problem have failed, contact the closest Princo sales representative in your area, or call the factory direct and ask for service assistance. The factory telephone number is 1-800-221-9237.

To assist us in providing an efficient solution to the particular problem, please have the following information available when you call:

1. Instrument Model Number
2. Probe Model Number
3. Purchase Order Number
4. Date of Purchase Order
5. Process Material being Measured
6. Detailed Description of the Problem

If your equipment problem can not be resolved "over the phone", then it may be necessary to return the equipment for checkout/repair.

Do not return equipment without first contacting the factory for a Return Authorization Number (RMA #).

Any equipment which is returned, MUST include the following information in addition to the list above.

7. RMA Number
8. Person to contact at your Company
9. Return (Ship to) Address

Princo level instruments are covered by a 10 year limited warranty. You will not be charged if it is determined that the problem is covered under warranty. Please return your equipment with freight charges prepaid. If repair is covered under warranty, Princo will pay return freight charges.

If telephone assistance or equipment return is not a practical solution to the problem, then it may be necessary for field assistance. Trained field servicemen are available from the factory on a time/expense basis to assist in these instances.